

## Cable hanger for HELIFLEX® Air-dielectric coaxial cable

Hangers for the installation of HELIFLEX® cables on different supporting profiles.  
Cable Clamp and Extended Counterbed hot-galvanized steel  
Screw: stainless steel.



picture shows the 1L4 version for illustration purpose only

### Technical Features

#### GENERAL SPECIFICATIONS

Product Line		Coaxial Cable Accessories
Product Type		Hanger
Hanger Type		Anchor bar 18-22mm (0.71-0.87")
Transmission Line Type		HCA214
Cable Type		Air Dielectric Coaxial Foam Dielectric

#### MECHANICAL SPECIFICATIONS

Cable Size		2-1/4"
Material		Cable Clamp : hot-dip galvanized Extended Counterbed : hot-dip galvanized Screw: Stainless steel
Recommended / Maximum Clamp Spacing	m (ft)	0.8 / 1 (2.75 / 3.25)

#### PACKAGING INFORMATION

Package Quantity		1
Weight per piece	kg (lb)	0.25 (0.55)

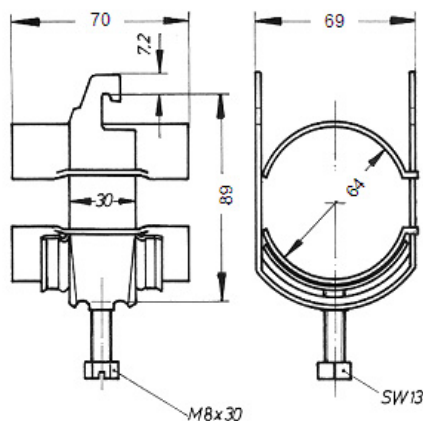

#### External Document Links

#### Notes

Hangers for anchor bar 18-22 mm (0.71-0.87")