

## Cable hanger for HELIFLEX® Air-dielectric coaxial cable

Hangers for the installation of HELIFLEX® cables on different supporting profiles.  
Cable Clamp and Extended Counterbed hot-galvanized steel  
Screw: stainless steel.



picture shows the 1L4 version for illustration purpose only

### Technical Features

#### GENERAL SPECIFICATIONS

Product Line		Coaxial Cable Accessories
Product Type		Hanger
Hanger Type		Angle iron 40mm (1.575")
Transmission Line Type		HCA38
Cable Type		Air Dielectric Coaxial Foam Dielectric

#### MECHANICAL SPECIFICATIONS

Cable Size		3/8"
Material		Cable Clamp : hot-dip galvanized Extended Counterbed : hot-dip galvanized Screw: Stainless steel
Recommended / Maximum Clamp Spacing	m (ft)	0.5 / 0.5 (1.8 / 1.8)

#### PACKAGING INFORMATION

Package Quantity		1
Weight per piece	kg (lb)	0.065 (0.14)

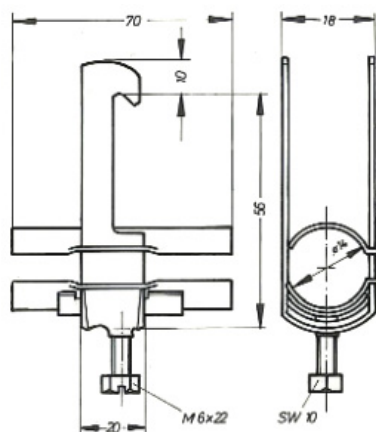

#### External Document Links

#### Notes

Hangers for angle iron 40mm (1.575")