



Cable hanger for HELIFLEX® Air-dielectric coaxial cable

Hangers for the installation of HELIFLEX® cables on different supporting profiles.
Cable Clamp and Extended Counterbed hot-galvanized steel
Screw: stainless steel.



picture shows the 1L4 version for illustration purpose only

Technical Features

GENERAL SPECIFICATIONS

Product Line		Coaxial Cable Accessories
Product Type		Hanger
Hanger Type		Flat iron 6-12mm (0.24-0.47")
Transmission Line Type		HCA400
Cable Type		Air Dielectric

MECHANICAL SPECIFICATIONS

Cable Size		4"
Material		Cable Clamp : hot-dip galvanized Extended Counterbed : hot-dip galvanized Screw: Stainless steel
Recommended / Maximum Clamp Spacing	m (ft)	0.8 / 1.2 (2.75 / 4)

PACKAGING INFORMATION

Package Quantity		1
Weight per piece	kg (lb)	0.77 (1.7)

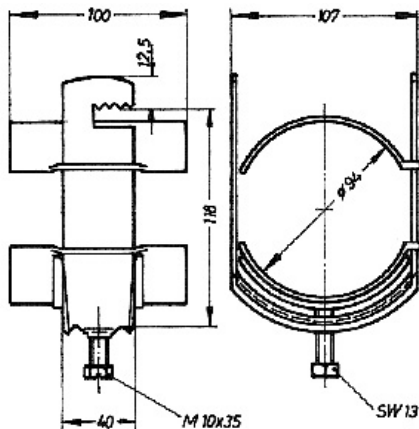

External Document Links

Notes

Hangers for flat iron 6-12 mm (0.24-0.47")