

# Cable hanger for HELIFLEX® Air-dielectric coaxial cable

Hangers for the installation of HELIFLEX® cables on different supporting profiles.  
Cable Clamp and Extended Counterbed hot-galvanized steel  
Screw: stainless steel.

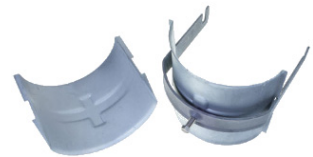

picture shows the 1L4 version for illustration purpose only

## Technical Features

### GENERAL SPECIFICATIONS

Product Line		Coaxial Cable Accessories
Product Type		Hanger
Hanger Type		Angle iron 40mm (1.575")
Transmission Line Type		HCA618
Cable Type		Air Dielectric

### MECHANICAL SPECIFICATIONS

Cable Size		6-1/8"
Material		Cable Clamp : hot-dip galvanized Extended Counterbed : hot-dip galvanized Screw: Stainless steel
Recommended / Maximum Clamp Spacing	m (ft)	1 / 2 (3.3 / 6.6)

### PACKAGING INFORMATION

Package Quantity		1
------------------	--	---

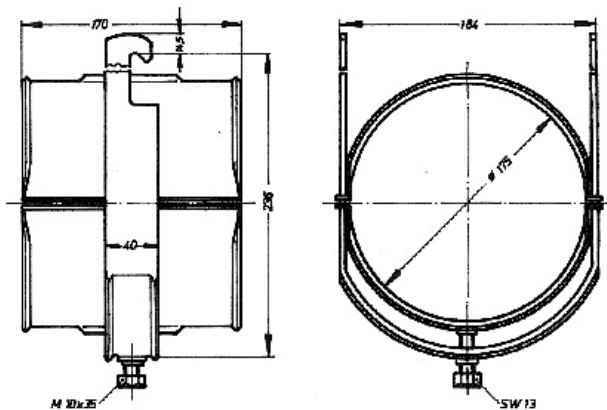

### HCH Clamps available for different types of interfaces:

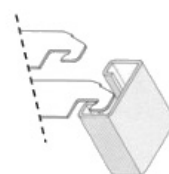

**Type C**  
For anchor bar  
(18-22mm slot)



**Type L**  
For angle iron  
(in different sizes)

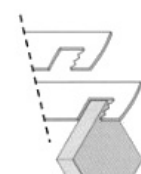

**Type R**  
For flat iron  
(6 – 12 mm)

### External Document Links

### Notes

Hangers for angle iron 40mm (1.575")